

# CASE STUDY

Manufacturing and Industrial  
Internet of Things



# Real-Time IoT Tracking and Visualization Improve Manufacturing

## Visualizing factory processes with IoT sensor data helps Shimane Fujitsu\* track product location and status, simplify prioritization, and save time and money

### At a Glance:

Fujitsu\* group developed a solution using the FUJITSU Cloud Service IoT Platform\* and Intel® IoT Gateway products to improve its product rework process. This solution provides several benefits:

- Gives a holistic real-time view of products during the rework process
- Helps reduce the probability of errors during the inspection process
- Helps decrease lead times and shipping costs
- Provides improvements for future process analysis

In order to improve the product rework process in its factory, Fujitsu Limited\* and Shimane Fujitsu Limited\* worked with Intel Corporation to jointly develop a proof-of-business value pilot using Internet of Things (IoT) technology to track product location and status. An advanced visualization solution provided real-time monitoring with maps and dashboard reporting, resulting in reduced lead times by up to 20 percent and reduced shipping costs by 30 percent associated with reworked products compared to the previous year.<sup>1</sup>

### Challenge

Shimane Fujitsu, a wholly-owned subsidiary of Fujitsu and a leading manufacturer of business notebooks and tablets, set out to improve processes where factory inspections found product errors. Prioritizing product rework based on shipping date was challenging, and it caused Shimane Fujitsu to incur additional shipping fees. Also, identified failures could often not be reproduced, which further delayed rework. The company needed a way to collect data to better track the location of products in the rework cycle as well as monitor progress in real time. The collected data would also help with process analysis for future improvements.

### Solution

Fujitsu Group and Intel jointly developed a solution using the FUJITSU Cloud Service IoT Platform\* and Intel® IoT Gateway products. Phase 1 involved using IoT sensors on products identified for rework. The solution provides a visual map of the rework area, including information about each product's location and status. With Fujitsu's distributed service platform technology, large volumes of sensor data can be processed in real time through a production information control system. Phase 2 of the pilot, which is ongoing, involves collecting video images of the inspection process for later analysis to provide a better understanding of why errors associated with rework products sometimes cannot be reproduced.

### Results

Workers can now reliably evaluate the status of products in the rework process, including when they are due to ship, which ones are delayed, and whether sensor batteries are low. With this ability, Shimane Fujitsu has improved its prioritization and management of rework products, reducing the lead times during the rework process by 15 to 20 percent. Shipping costs for reworked products have also been reduced by 30 percent.



Improved prioritization and management of rework products result in:



**20%<sup>UP TO</sup> REDUCTION IN LEAD TIMES**

and

**30% REDUCTION IN SHIPPING COSTS<sup>1</sup>**

## Edge Computing and IoT Transform Manufacturing

Factory management has evolved over the decades to meet the competitive challenges of today by using highly sophisticated automation processes. Factories now use edge computing and IoT to extract real-time data for automated control systems. This data is categorized and prioritized for ongoing analysis and decision making. With these real-time capabilities and virtualization, automation capabilities based on Intel IoT Gateway products and the FUJITSU Cloud Service IoT Platform provide a competitive advantage in using IoT and edge computing in manufacturing.

Intel's investment in real-time data and automation delivers increasingly complex and higher quality products. Intel has been automating manufacturing for decades, which has involved significant investments in technology, people, and processes.

### Understanding the Cause and Status of Reworked Product Can be Difficult

Shimane Fujitsu produces 30 million computer devices annually, along with approximately 2 million customized devices, using just-in-time manufacturing, meaning products are assembled and shipped to fulfill incoming orders. Assembled products are inspected both automatically and manually at Shimane Fujitsu to ensure the highest quality. Products that do not pass inspection are collected in a rework area where causes of the failure during inspection are diagnosed and corrected. Once the product is reworked it undergoes additional inspection as a part of the rework process before shipping.

In the past, not every product in the rework area was tracked electronically, making it difficult to identify the location of each one on demand. In addition to understanding the location and status of reworked products, identifying the cause of the failure also presented challenges. Problems identified during

### Spotlight on Shimane Fujitsu\*

Shimane Fujitsu is one of Japan's largest manufacturers, producing notebooks and tablets from the system board all the way to the finished product. It operates two 23,000 square-meter factories and employs 1,100 workers. Many models of business notebooks and tablets are produced in small lots and are custom-made for individual customers. Shimane Fujitsu produces 30 million computer devices annually.

initial testing are sometimes difficult to reproduce because of human error, faulty products or parts, or even a failure within the testing equipment. Shimane Fujitsu wanted to observe correlations between error information and data from past rework scenarios to help them understand why these errors were difficult to reproduce. Through this initiative, Shimane Fujitsu plans to increase overall efficiency through improved product quality using rapid feedback.

### IoT Technology Reduces Rework Lead Time and Shipping Costs

Fujitsu group and Intel assembled a team to develop a joint solution to visually track rework products by location and status, as well as to collect data for later analysis of rework causes. The team used Fujitsu's distributed service platform technology for analyzing real-time data and Intel IoT Gateway products for acquiring and transmitting sensor data to the IoT Platform (see Figure 1). Intel IoT Gateway products were selected based on their overall ability to meet the demands of the solution, particularly for processing the massive data load of video content.

The pilot was divided into two phases: visualizing the rework process and visualizing the rework inspection process.

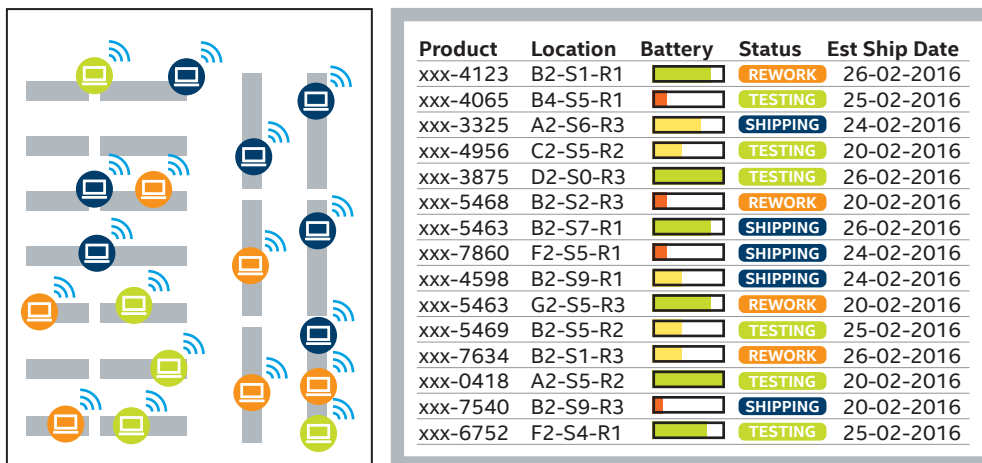

Figure 1. The Intel® IoT Gateway collects and transmits product data to the FUJITSU Cloud Service IoT Platform\*. Fujitsu's distributed service platform technology visually displays the location and status of the product in the rework area in real time.

### Phase 1: Visualization of the Rework Process

Phase 1 of the solution visualized the location and status of products in the rework process through an intuitive format for quick response. When a product entered the rework area a sensor was attached and scanned to associate it with the product number to track its physical location. Data was then collected through the Intel IoT Gateway and sent to the IoT Platform.

Using the IoT Platform, running on Intel® Xeon® processors, sensor data was processed in real time, displaying the location and status of each product on a map. The map included alerting icons to identify products with specific ship dates, products that are delayed by more than 30 and 60 minutes, or when the sensor battery was low (see Figure 2). Location and status information was provided to the factory manager through a desktop interface, as well as displayed on a large monitor in the rework area so that all workers could immediately identify the progress of any product. Workers could also search for specific products by number or shipping date.

Visualizing the location and status of products for immediate prioritization allowed Shimane Fujitsu to eliminate wasteful delays and reduce the lead time of rework products by up to 20 percent. It also reduced additional shipping costs associated with rework products by 30 percent compared to the previous year.

### Phase 2: Collecting Visual Data from the Inspection Process

With phase 1 successfully completed and plans underway to implement it across multiple factory locations, the pilot team focused on phase 2, which is in progress. Phase 2 of the pilot captures and analyzes video images of the inspection process, focusing on just one of the 20 production lines at Shimane Fujitsu. Video data is collected during inspection and transmitted through the Intel IoT Gateway to a file server while metadata, such as transmission time, product number, and video file path—acquired using optical character recognition (OCR)—is sent to the FUJITSU Cloud Service IoT Platform. This data provides the line supervisor with a visual representation of every product, its error, and the inspection status.

### Technical Components of the Solution

- **FUJITSU Cloud Service IoT Platform\***. Fujitsu's distributed service technology provides dynamic processing at the gateway and in the cloud. This end-to-end platform combines sensors, devices, networks, middleware, and application integration.
- **FUJITSU Cloud Service K5\***. This open source-based platform provides large-scale service infrastructure for public cloud, virtual private hosted cloud, and dedicated on-premises solutions.
- **Intel® Xeon® processor E5 v4 family**. The Intel Xeon processor E5 v4 family offers outstanding performance and capabilities for software-defined infrastructure, supporting cloud architecture and highly-efficient workload management in the data center and cloud.
- **Intel® IoT Gateway products**. Intel IoT Gateway products provide performance and security for data at the edge, enabling near real-time analysis and tighter, more efficient process controls, while reducing data transmission costs.
- **Intel® Atom™ processor**. The Intel Atom processor E3800 product family is excellent for IoT use, delivering outstanding compute, graphical, and media performance while operating in an extended range of thermal conditions.

“The position of the rework product is pinpointed in real time and never lost because tracking continues wherever it goes. In addition, we can determine, at a glance, which products must be shipped by priority, so we never miss anything. Workers always start with products that have priority shipping.”

—Kensuke Esumi  
Test Engineer  
Shimane Fujitsu

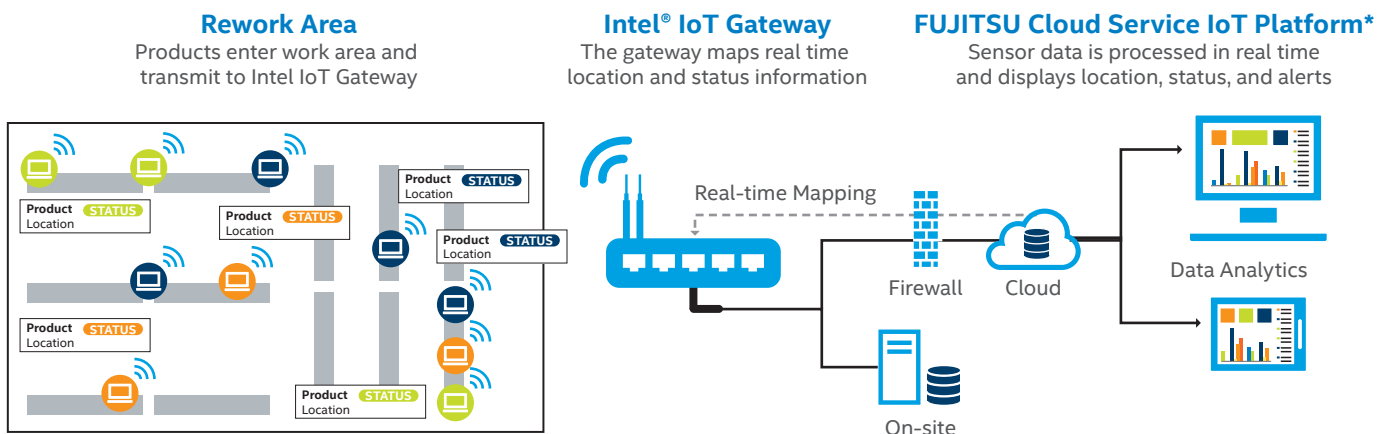

**Figure 2.** With IoT sensor data, a visual map of the rework area displayed each product-site location and status. This made it easy to see when items were due to ship, if they were delayed, or if the sensor battery was low.

Shimane Fujitsu is planning a full verification of video images and associated metadata. The project team expects to correlate the analysis of error data with historical rework data for better insights into the causes of rework. They intend to use this information to increase the production yield of finished products and decrease the number of products that go through rework.

“We are considering using sensors to compare on-site simulation tools and digitalize the circulation of workers. This will allow us to learn which areas tend to fall behind in work and analyze bottlenecks. We can also review the arrangement of parts to modify worker circulation.”

—**Shinichi Hirono**  
Manager, Manufacturing Engineering  
Shimane Fujitsu

## Shorter Lead Times and Lower Shipping Costs

By developing an IoT-based solution to track products in the rework process and visualize the rework inspection process, Shimane Fujitsu is now able to easily manage work based on priority. The company is also discovering deeper insights into how to prevent errors that cause rework. Managers and line workers can reliably evaluate where products are in the rework cycle, as well as physically within the area, and prioritize work accordingly. The visual mapping has helped Shimane Fujitsu reduce rework lead time by 15 to 20 percent.

Because reworked products are often delayed, meeting customer expectations for delivery often requires costly expedited shipping arrangements. Now that Shimane Fujitsu can easily prioritize rework products by shipping date, the company has saved approximately 30 percent on shipping costs over the previous year.

The pilot has also opened new opportunities for using visualization to improve other processes in the factory.

### Solution Provided By:



Fujitsu and Shimane Fujitsu are planning to use big data to analyze the data collected from the rework products and processes to identify production errors and improve yield. Fujitsu is also considering expanding visualization from the factory to the entire supply chain as the optimized production solutions using the FUJITSU Cloud Service IoT Platform can help other manufacturers. It can also facilitate cooperation between Fujitsu's cloud architecture and Intel IoT Gateway products, pursuing a more sophisticated IoT platform.

“High processing power is needed to transform the inspection code from images into text with optical character recognition and to extract metadata from the video. We used Intel® IoT Gateway to handle the large data loads. We also learned how useful this technology will be in other situations moving forward.”

—**Kazuhiro Chisaki**  
System Developer, IoT Business Division  
Fujitsu Limited

## Secure, Scalable Data Transmission with Intel® IoT Gateway Products

Intel IoT Gateway products secure data transmission between sensors, edge devices, data centers, and cloud environments, helping to implement IoT-based solutions. Intel IoT Gateway products collect and process data from devices using powerful Intel® Quark™, Intel® Atom™, and Intel® Core™ processors. Intel IoT Gateway products integrate management functions such as networking, embedded control, and security, allowing rapid development and scalability of enterprise IoT solutions.

Find the solution that is right for your organization. Contact your Intel representative or visit the [Industrial Automation site](#).

### Learn More

You may also find the following resources useful:

- [Fujitsu Boosts Efficiency of Manufacturing Processes at Shimane Fujitsu through IoT Collaboration with Intel](#)
- [Why Businesses Should Choose IoT for Manufacturing](#)
- [Internet of Things \(IoT\): Smart Manufacturing](#)
- [Network Enhancement Solutions for the IoT Era](#)

<sup>1</sup> Fujitsu Boosts Efficiency of Manufacturing Processes at Shimane Fujitsu through IoT Collaboration with Intel, [www.fujitsu.com/global/about/resources/news/press-releases/2016/0519-01.html](http://www.fujitsu.com/global/about/resources/news/press-releases/2016/0519-01.html).

All information provided here is subject to change without notice. Contact your Intel representative to obtain the latest Intel product specifications and roadmaps.

Intel technologies' features and benefits depend on system configuration and may require enabled hardware, software, or service activation. Performance varies depending on system configuration. No computer system can be absolutely secure. Check with your system manufacturer or retailer, or learn more at [intel.com](http://intel.com).

System configurations, SSD configurations and performance tests conducted are discussed in detail within the body of this paper. For more information go to [intel.com/performance](http://intel.com/performance).

Cost reduction scenarios described are intended as examples of how a given Intel- based product, in the specified circumstances and configurations, may affect future costs and provide cost savings. Circumstances will vary. Intel does not guarantee any costs or cost reduction.

No license (express or implied, by estoppel or otherwise) to any intellectual property rights is granted by this document.

THE INFORMATION PROVIDED IN THIS PAPER IS INTENDED TO BE GENERAL IN NATURE AND IS NOT SPECIFIC GUIDANCE. RECOMMENDATIONS (INCLUDING POTENTIAL COST SAVINGS) ARE BASED UPON INTEL'S EXPERIENCE AND ARE ESTIMATES ONLY. INTEL DOES NOT GUARANTEE OR WARRANT OTHERS WILL OBTAIN SIMILAR RESULTS.

INFORMATION IN THIS DOCUMENT IS PROVIDED IN CONNECTION WITH INTEL PRODUCTS. NO LICENSE, EXPRESS OR IMPLIED, BY ESTOPPEL OR OTHERWISE, TO ANY INTELLECTUAL PROPERTY RIGHTS IS GRANTED BY THIS DOCUMENT. EXCEPT AS PROVIDED IN INTEL'S TERMS AND CONDITIONS OF SALE FOR SUCH PRODUCTS, INTEL ASSUMES NO LIABILITY WHATSOEVER AND INTEL DISCLAIMS ANY EXPRESS OR IMPLIED WARRANTY, RELATING TO SALE AND/OR USE OF INTEL PRODUCTS INCLUDING LIABILITY OR WARRANTIES RELATING TO FITNESS FOR A PARTICULAR PURPOSE, MERCHANTABILITY, OR INFRINGEMENT OF ANY PATENT, COPYRIGHT OR OTHER INTELLECTUAL PROPERTY RIGHT.

Copyright © 2016 Intel Corporation. All rights reserved. Intel, the Intel logo, Intel Atom, Intel Core, Quark, and Xeon are trademarks of Intel Corporation in the U.S. and/or other countries.

\*Other names and brands may be claimed as the property of others.

0916/JKER/KC/PDF

♻️ Please Recycle

334846-001US